

# BP-Mount Beltpack Mounting Kit

Intercom Accessories



Linking  
People  
Together



BP-Mount Kit

## Key Features and Benefits

- Universal mount for Encore, HelixNet and FreeSpeak II beltpacks
- Able to hold tablets and beltpacks individually or at the same time
- Desk, Screw or Velcro strap mounting
- Locking fit

The BP-Mount is a universal beltpack mounting kit for Encore, HelixNet and FreeSpeak II beltpacks.

## Description

The BP-Mount provides a simple solution to provide a non-permanent surface, upstand or wall mount for Encore, HelixNet and FreeSpeak II beltpacks. This is a way to secure a wired or wireless beltpack when in use for easy access. The BP-Mount is also able to support a small tablet, even when the beltpack is in use. The BP-Mount is stackable for ease of storage.

---

## Technical Specifications

### Dimensions

1.67 x 4.2 x 4.7 in. (HxWxD)  
(43 x 107 x 109 mm)

### Weight

2 oz (0.06 kg)

# BP-Mount Backpack Mounting Kit

Intercom Accessories

## Front Angle

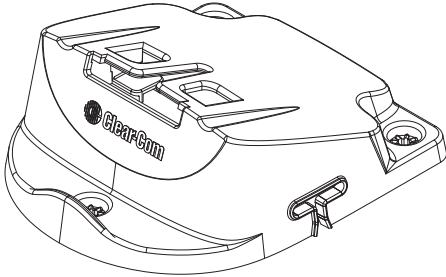

## Back Angle

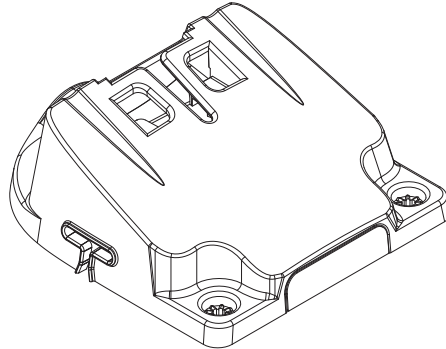

## Holder with Backpack

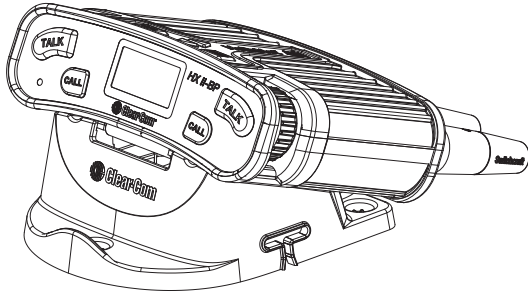

## Holder with Backpack and Tablet

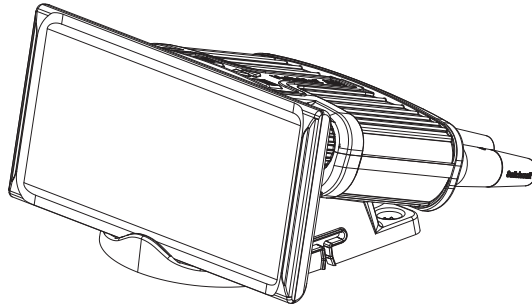

**Order Code**

**BP-Mount**